

# MANUAL DE MONTAJE

## F2



### **MAMPARA FRONTAL DE DUCHA**

1 HOJA CORREDERA + 1 FIJA

## F2

# 1

PRESENTAR "U" EN PARED  
Y MARCAR LOS TALADROS

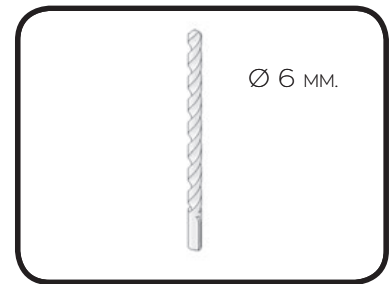
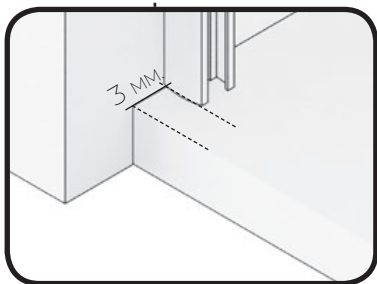

# 2

TALADRAR CON  
BROCA Ø 6 MM.



# 3

ATORNILLAR LA "U" A PARED  
USANDO TACOS DE N° 6  
TORNILLOS 4,2 x 32.



# 4

COLOCAR GOMA ESTANQUEIDAD INFERIOR FIJO E INTRODUCIR EL CRISTAL FIJO EN LA "U" APOYANDO SOBRE ÉSTA.

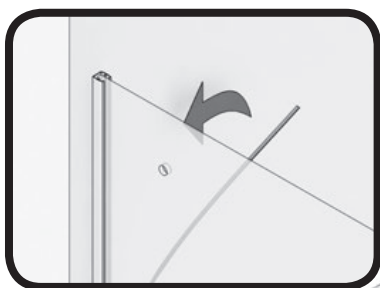

# 5

ENGOMAR CRISTAL FIJO A "U" Y COLOCAR LA PINZA GUÍA INFERIOR EN EL EXTREMO DEL VIDRIO.

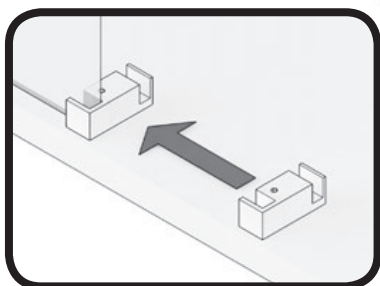

PINZA GUIA INFERIOR

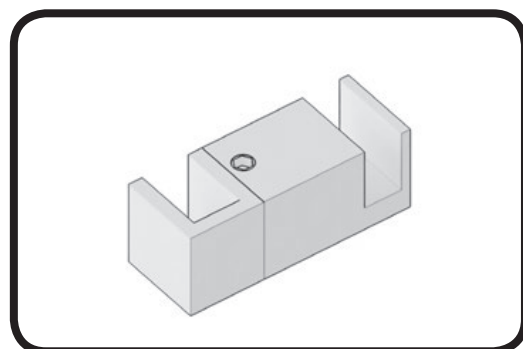

F2

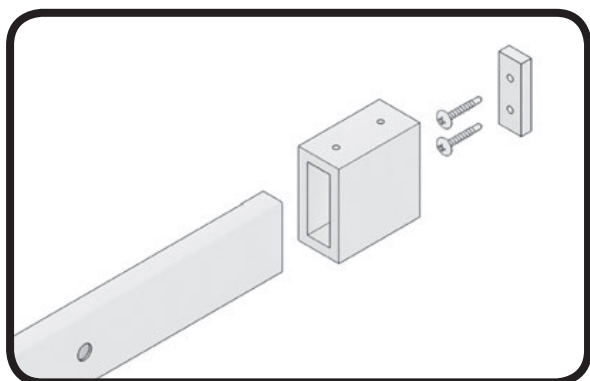
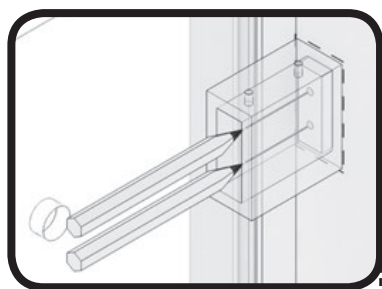

DESMONTAR PLACA BASE DEL SOPORTE VASO, SOLTANDO EL TORNILLO PRISINERO, MARCAR TALADROS.

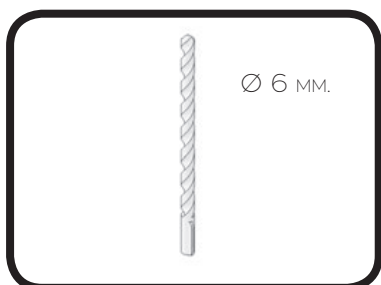

Ø 6 MM.

7

TALADRAR CON BROCA DE Ø 6 MM.



RETIRAR CRISTAL FIJO SI FUESE NECESARIO..

6

PRESENTAR GUÍA SUPERIOR CON LOS VASOS SOBRE EL VIDRIO FIJO, HACIENDO COINCIDIR LOS TALADROS GUÍA CON LOS DEL VIDRIO, NIVELAR Y MARCAR EL CONTORNO EXTERIOR DE LOS VASOS..



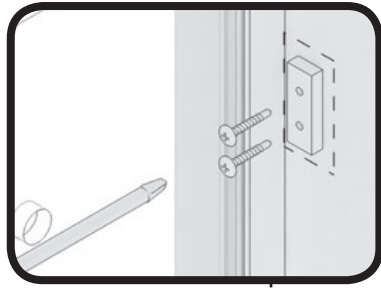

# 8

ATORNILLAR LA PLACA BASE SOPORTE GUÍA SUPERIOR COGIDA A PARED.



# 9

INTRODUCIR EL TOPE FRENO EN LA GUÍA, Y LOS VASOS SOPORTE GUÍA.

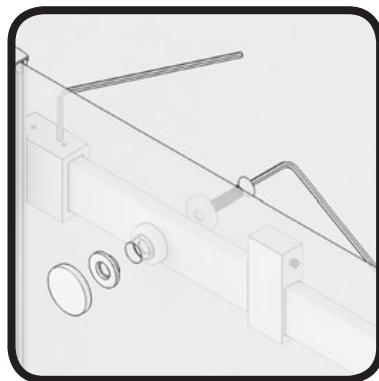
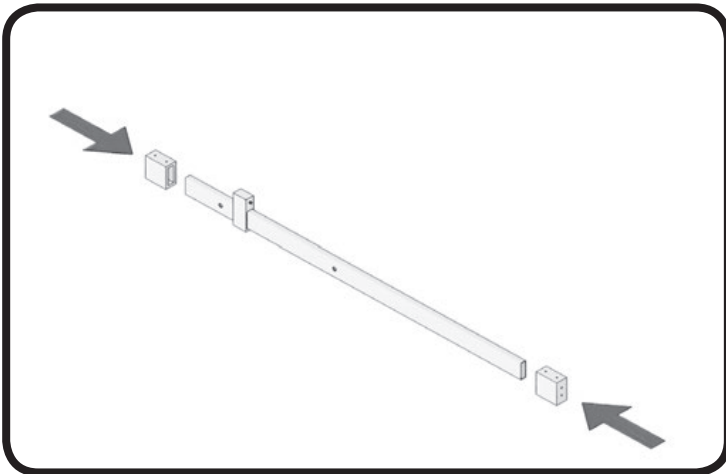

# 10

COLOCAR LA GUÍA SUPERIOR EN LAS BASES COGIDA A PARED, FIJAR LA COGIDAS A LA GUÍA Y ESTA A LOS TALADROS DEL FIJO CON LAS SUJECIONES.

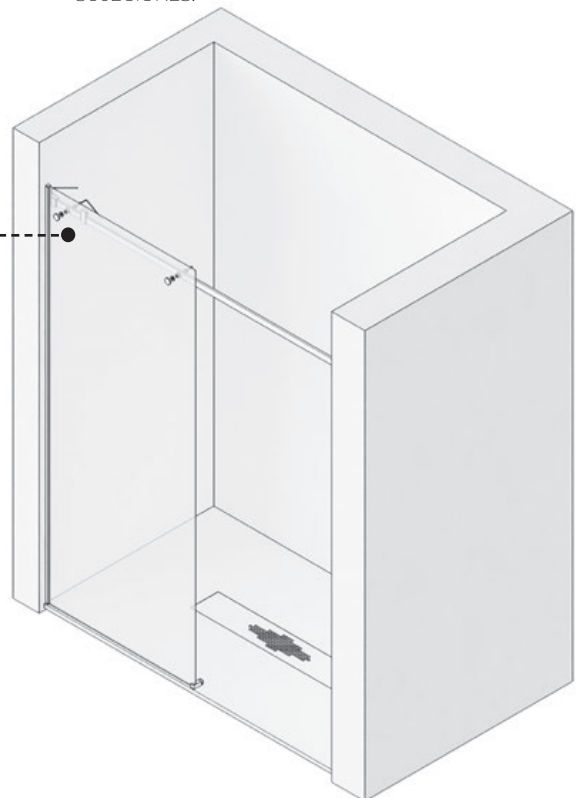

# 11

COLOCAR LOS RODAMIENTOS EN LA HOJA CORREDERA, COLGAR LA PUERTA INTRODUCIENDO PREVIAMENTE LA GOMA DE "U" EN EL CANTO INFERIOR. GRADUAR RUEDAS, GIRANDO CON LA LLAVE ALLEN ANTES DE FIJAR.

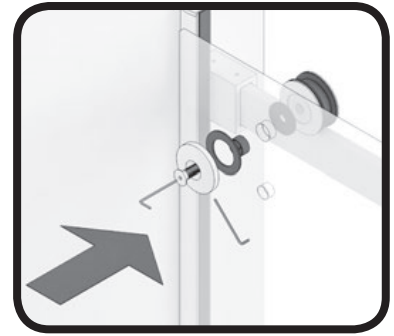
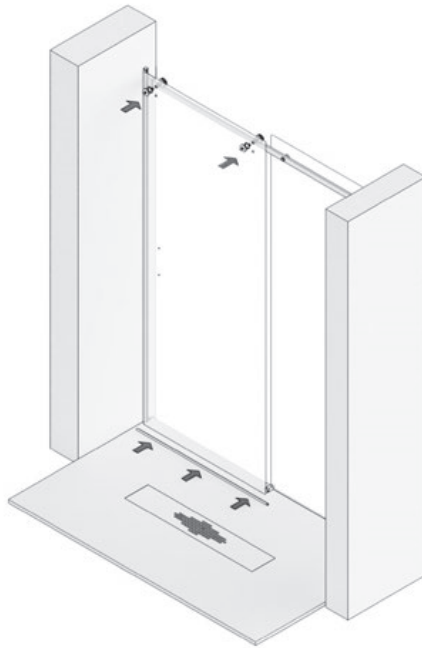

# 12

MONTAR Y AJUSTAR LOS PERNOS ANTIVUELCO, COLOCAR EL ASA TIRADOR.

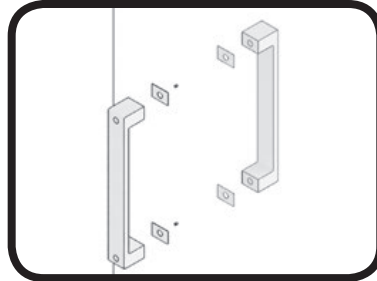
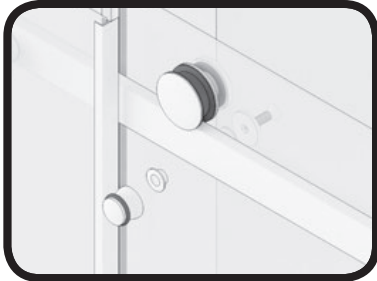

# 13

COLOCAR LAS GOMAS DE CRUCE, UNA EN EL FIJO Y OTRA EN LA HOJA CORREDERA. COLOCAR EL CIERRE GOMA IMÁN EN EL EXTREMO DE LA HOJA CORREDERA Y PRESENTAR SOBRE EL MISMO EL PERFIL "U" IMÁN A PARED. INTRODUCIENDO PREVIAMENTE EL TERMINAL VIERTE AGUAS INFERIOR. APROXIMARLO AL CIERRE PARA MARCAR Y COLOCAR.

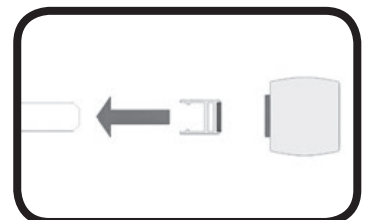
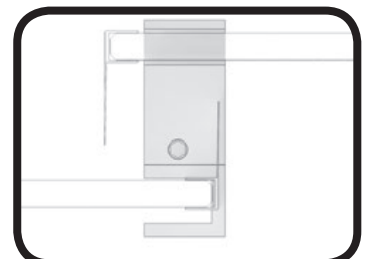
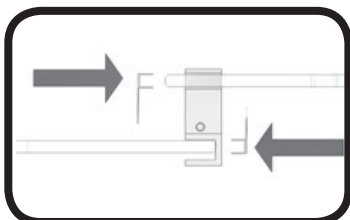

# 14

FIJAR EL TOPE FRENO MEDIANTE EL TORNILLO PRISIONERO..

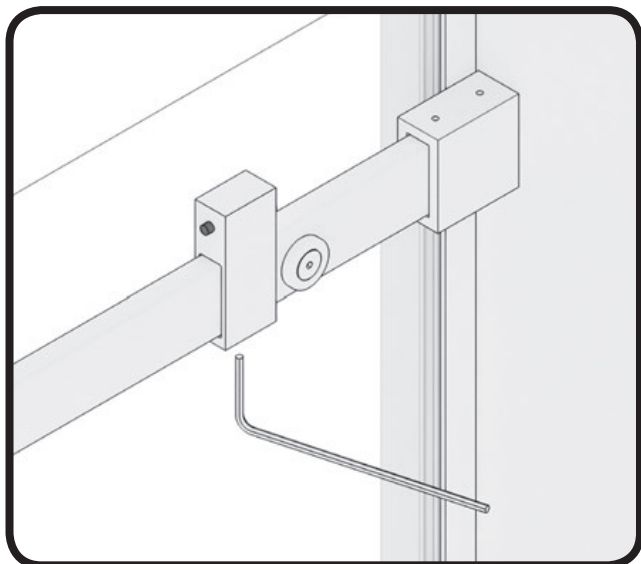

# 15

CORTAR EL PERFIL BAJO A MEDIDA. DESDE LA PINZA BAJA HASTA PARED Y COLOCAR POR DELANTE DE LA HOJA CORREDERA.



# 16

PEGAR PERFIL BAJO CON SILICONA.

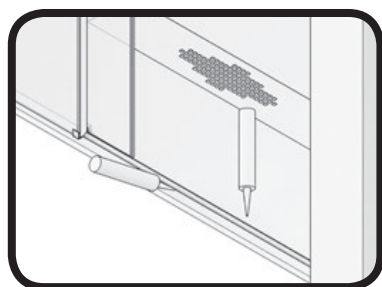

# 17

SELLAR CON SILICONA EL CONTORNO EXTERIOR DE LA MAMPARA.



# F2

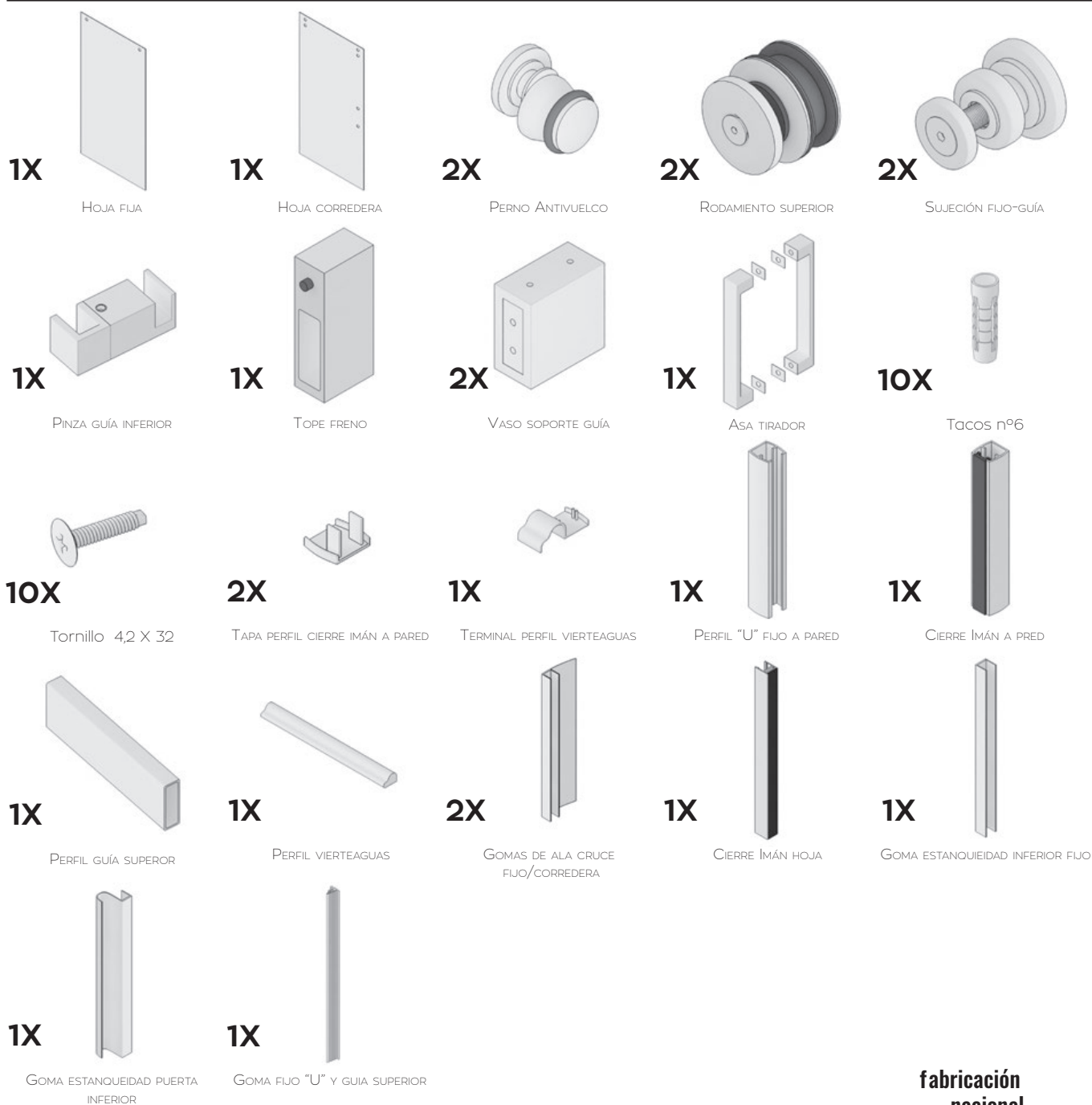
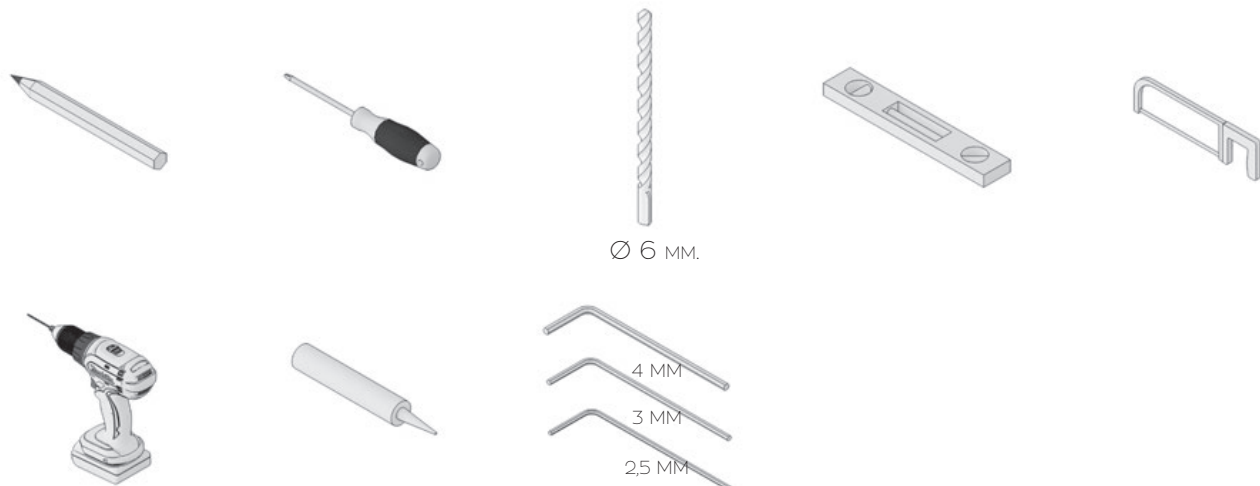

**fabricación nacional**